

TRANSFORMER-LESS PASSIVE LED DRIVER

Suresh Kumar A¹, Sunil Kumar V², Kalyanasundaram V³,
Vidyasagar S⁴

^{1,3,4}Assistant Professor, Department of EEE, SRM Institute of Science and Technology, Tamil Nadu, India

²Associate Professor, EEE Department, St. Martin's Engineering College, Secunderabad, Telangana

Abstract-

The main idea of this paper is to design a transformer-less Light Emitting Diode (LED) driver circuit using capacitors. A constant voltage driver circuit is required to increase the life span of LEDs and reduce heat dissipation. Ripple current tends to increase the heat which is the major disadvantage in a LED circuit. Another limitation is due to additional components which results in high cost and low power density. This paper deals with new topology for LED driving with reduced number of components. To reduce the heat loss, a heat sink was designed using conventional method. This study gives an economical approach. The proposed method achieves the efficiency and effectiveness with low output current ripple.

Keywords: LED driver, capacitor, transformer-less, heat sink

INTRODUCTION

A light-emitting diode (LED) is a two-lead semiconductor light source. It is a p-n junction diode that emits light when activated. It releases energy in the form of photons when recombination of electron and electron holes take place. This is called electroluminescence. It is widely used as indicators and signs, backlighting, data communication and other lighting, light source for machine vision system, optical fiber, and free space optic communication.

LED has high efficiency, low cost, long lifespan, small size and it solves energy and environment problems by saving power. It has wide range of colours and is difficult to damage with external shock. Other bulbs like incandescent and fluorescent lamps are fragile in nature. LEDs are shock resistance. It requires very less warm-up time. It

achieves full brightness with faster response time. LEDs initial cost is high. The major disadvantage is that its efficiency decreases as electric current increases. Heat sink should be proper otherwise it leads to losses.

Every LED requires a LED driver circuit. This is to provide stable current for same luminance. Driver circuit should be highly efficient, simple, and cost effective. Since paper is based on transformer less LED driver circuit using capacitors, a balancing capacitor can be selected for simple topology.

Many papers have proposed that using fly back or tapped boost converter with balancing capacitor can be used. It is easy to design but it may lead to high voltage stress on main switch. It is because of the energy stored in leakage inductor of magnetic components. This energy can be reset by RCD snubber circuit[2]. This is not enough. Ideal snubber circuit must be used in order to increase its efficiency. Otherwise, dissipation of energy takes place. For ideal snubber circuit we require additional components thus leading to increasing cost and power density.

As mentioned in some papers, boost converter must be used which is perfect for many number of LEDs in series. Now all LED will same current so no mismatch issues[1]. But the disadvantage is gain of boost converter. For dc gain > 10, high steady state duty cycle should be greater than 90%. This will have high di/dt value. In order to increase duty cycle high switching frequency is required. But it requires control switch to switch fast otherwise diode will not have enough time to conduct current. It will also have a latch up problem. Losses increases with output voltage.

To provide stable current to LEDs dimming control technology is used. E.g. TRIAC dimmer. Single stage power factor fly back converter[3]. This increases output current ripple which is very dangerous. To avoid ripple current a capacitor should be placed in parallel is required. High PFC can cause TRIAC to operate unstably. This stabilization is difficult to obtain.

In this paper we will use transformer-less LED driver circuit with capacitor in parallel along with zener diode and bridge rectifier and reduced number of components. Many LEDs can be kept in series if required. Bridge rectifier is used to convert ac to variable dc. Since capacitor is placed in parallel it will reduce the ripple current in second filter. The first filter is used filter dc and gives first stage filter. The series resistance is used to limit the current to LED. Zener diode is used to give constant dc voltage to the LED. There is no transformer so it is light weight.

EXPERIMENTAL PROGRAM

Fig 1 shows the proposed transformer less LED driver. The bridge rectifier used for convert the alternating signal to direct signal. The source side uses for LC filter to reduce the harmonic in source side. The Zener diode used for cut the negative current in load side. The driver used for only passive components, so no need for controller circuit. The load side capacitor used for reduced ripple in load side. The LED act as a current controlled non linear device.

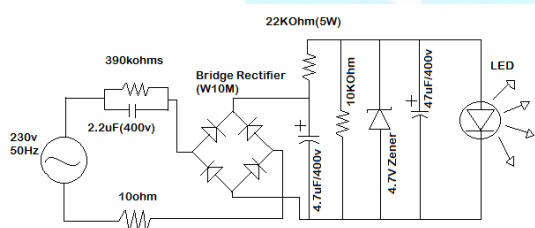

Figure .1 Proposed Circuit Topology of Transformerless Capacitor based LED driver circuit.

A. Components used

- Resistors Used: 390k Ohm, 10 Ohm, 22KOhm(5W), 10K Ohm.
- Capacitors: 2.2uF(400V), 47uF/400V, 47uF/25V
- Bridge Rectifier: 10Mw, 350V ac to 350V dc

- Zener Diode: 3V
- LED: 2.8V, 3.7mA

B. Design and development

- First 22 µF capacitor is connected across 230V and its use is to limit the AC current from the supply.

- The nature of current passed through that 1st capacitor is found by formula:-

$$X_c = 1/2 * (\pi * F * C), \text{ where } C = 2.2 \mu\text{F}.$$

- The current through it is found by Ohms Law is used for discharging of capacitor, when supply is OFF.

- The 10Ω resistance is acting as a fuse.

- The bridge rectifier 400V is used to connect AC to DC.

- 400V is taken because as our supply is 250 Vrms value and its max value = $V_{rms} * \sqrt{2}$.

$$\text{MAX value} = 230 * 1.414325 = 16V.$$

- The 47 µF capacitor is used to reduce the ripples at first stage.

- The resistor $R_s = 22K\Omega$ is used to limit the current to load. Its value found by formula,

$$R_s = (V_{in} - V) / (I_L + I_Z)$$

$$R_s = (305 - 3) / (4 + 10) * 10^{-3}$$

- Zener diode used is of 3V.

- Capacitor of 47 µF is used for last filtration purpose.

- The resistance of LED is:-

$$R = V / I$$

$$R = 3V / 4mA = 750\Omega.$$

C. Numerical analysis

The aim of our research on LED Driver circuit is basically to design a transformer less LED driver circuit using a heat sink conventional materials. It is required for LEDs to increase their lifetime, provide constant voltage to it, reduce the heat with very less ripples and also cost effective. First 2.2 UF capacitor is connected across 230V and its use is to limit the ac current from the supply. The value of reactance across it is found by the formula:-

$$X_C = 1 / 2 * \pi * F * C \quad (C = 2.2\mu\text{F})$$

The current through it if found by the formula, that is $V = IR$. The resistance in parallel to it is 390K ohm is used for discharging of capacitor, when supply is off. The 10 Ohm resistance is acting as a fuse. The bridge rectifier 400V is used here to convert ac to dc. 400V is taken because as our supply is 230V RMS value and its maximum value = $V_{rms} * \sqrt{2}$.

Max value = $230 \times 1.41 = 325.16V$ so we are taking our components of 400 voltage. The 47uF capacitor is used to reduce the ripples at first stage. The resistor $R_s = 22Kohm$, is used to limit the current to the load. Its value is found out by the formula,

$$R_s = (V_{IN} - V_Z) / (I_L + I_Z)$$

Zener diode used is of rating 3V. Capacitor of 47uF is used for last filtration process. The resistance of

LED is found to be, $R = V/I$. This is basically the load that has been connected to the proposed driver circuit.

D. Simulational circuit

The fig 2 shows the proposed converter simulation diagram. The equivalent resistor used for LED load. Based on the design parameters used for simulation components.

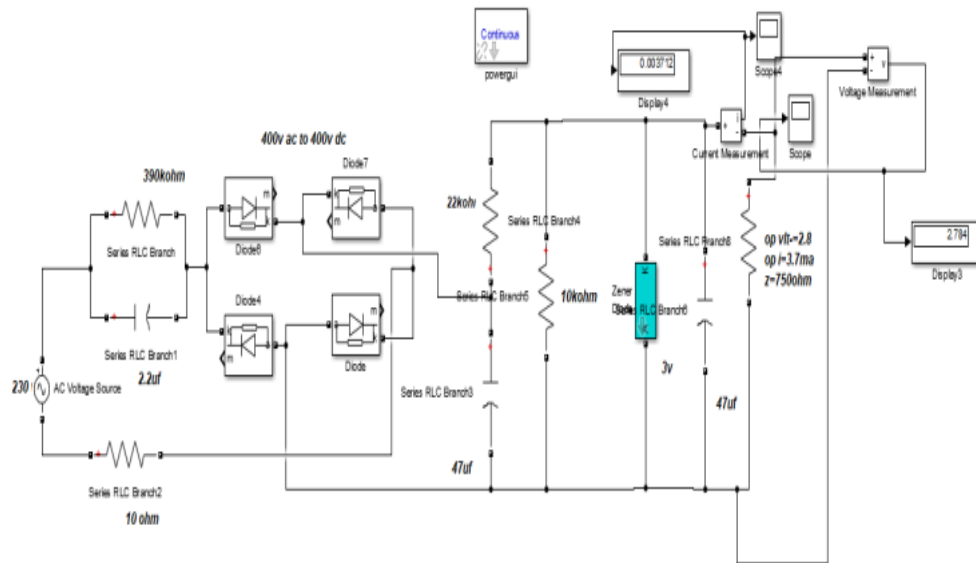

Figure.2 Simulation Circuit of Proposed topology in MATLAB.

SIMULATIONAL RESULT

The fig 3& 4 shows the output voltage and current waveforms. The values were get in 2.732 V and 3.5 mA. The voltage and current reach quick settling time in proposed converter and maintain the constant value.

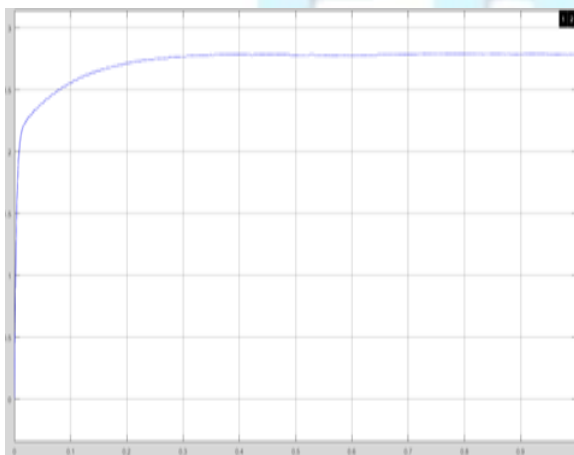

Figure 3 – Output voltage waveform

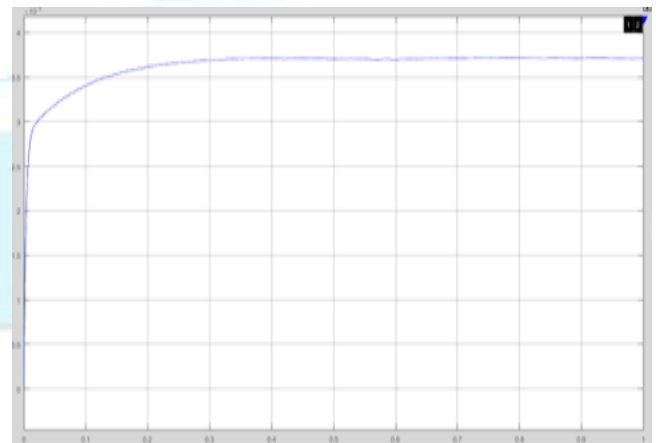

Figure 4 – Output current waveform

CONCLUSION

The proposed circuit enable us to make less use of transformers. Other advantages of the proposed converter include inherent open-circuit and shortcircuit protections, zero-voltage switching for the bridge transistor and zero-current switching for the output rectifier diodes, simple dynamics,

possibility of analog and pulse width modulation dimming, constant switching frequency operation, and high efficiency.

RESEARCH SIGNIFICANCE

- There are many other possibilities for LED driver circuit, specially lower safe voltages.
- Light dimming can be avoided.
- As LED is a very good future lightning source. So the circuit is used to increase the life of our future light.

REFERENCES

[1]. Rong Guo, Student IEEE member, Future Renewable Electric Energy Delivery and Management System Centre, North Carolina State University, USA.

[2]. Mitsuhiro Kadota and Hiroyuki Shoji Hitachi Ltd, R and D group, Japan, A New Bleeder Circuit for TRIAC Dimmable LED Driver Based on Single-Stage Topology with a Capacitor Input Rectifier.

[3]. Jong-Woo Kim ,Future Energy Electronics Center, Virginia Tech, Blacksburg, VA, USA, Forward-Flyback Converter for LED Driving with Reduced Number of Components.



IJREAT
PRDGG